

Verstellung +/- 15 mm

Material: Stahl
Oberfläche: Matt vernickelt
Verchromt

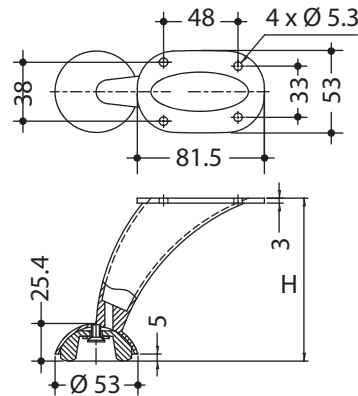

Möbelfuss fix,
ohne Höhenverstellung,
mit Gleiter aus Gummi

Material: Zinkdruckguss
Oberfläche: Matt vernickelt
Verchromt

H(mm)	Art.
105	T634.105
130	T634.130

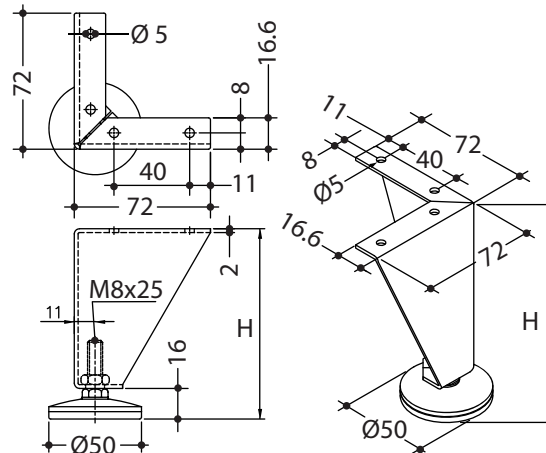
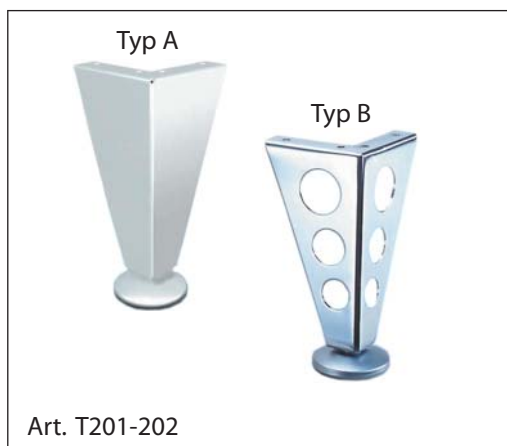

Möbelfuss aus Stahlblech,
Verstellung +/- 25 mm

Material: Stahl
Oberfläche: Matt vernickelt
Verchromt

H(mm)	Art.
100	T201.100
150	T201.150

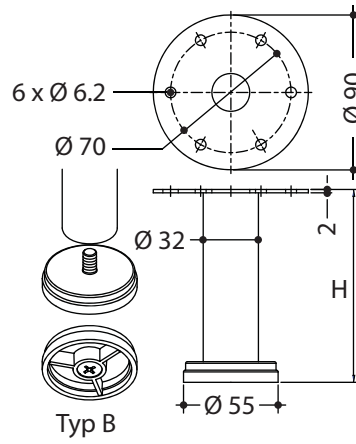

Rohr-Ø 32 mm
Teller - Zinkdruckguss
Typ A: fester Fuss
Typ B: Verstellung +/- 5mm

Material: Stahl
Oberfläche: Matt vernickelt
Verchromt

H(mm)	Art.
100	T131B.100
120	T131B.120
150	T131B.150
180	T131B.180

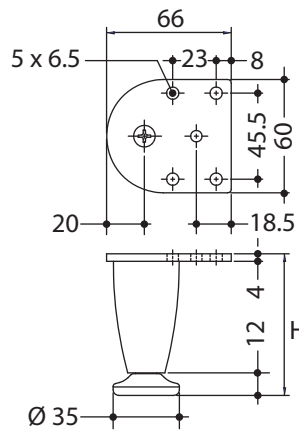

Stahl Anschraubplatte 4 mm
Verstellung +/- 10 mm

Material: Zinkdruckguss
Oberfläche: Matt vernickelt
Verchromt

H(mm)	Art.
50	T603.50
75	T603.75
100	T603.100

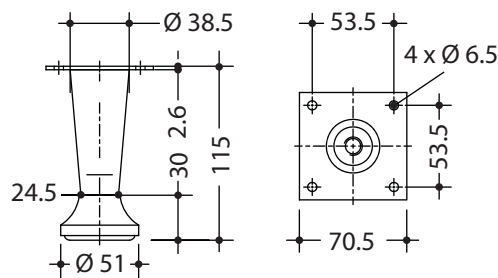

Verstellung +/- 15 mm
Höhe: 115 mm

Material: Zinkdruckguss
Oberfläche: Matt vernickelt
Verchromt

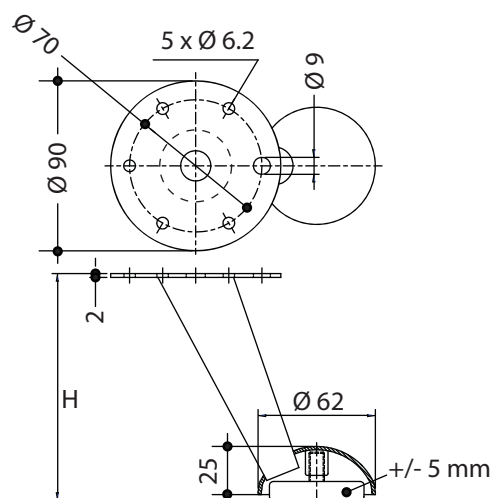

Rohr-Ø 38 mm (verjüngt)
Neigung 65°

Material: Stahl
Oberfläche: Matt vernickelt
Verchromt

H(mm)	Art.
120	T001B.120
150	T001B.150
180	T001B.180